



HF-Regulator Intelligent Touch DALI for TL5/TL-D/PL-L lamps

HF-Ri TD 2 14/21/24/39 E+

This intelligent high-frequency electronic dimming ballast utilizes the DALI or Touch and Dim push-button protocol for fluorescent lamps. It meets A1BAT requirements, thereby pre-empting upcoming legislation. With a special command you can retrieve the system's mains power consumption, and with another you can find out which lamp wattage is connected. Combined with controls, additional energy savings can be achieved. The ballast is primarily designed for Indoor application. For outdoor application, the luminaire should be minimum Class II and need to be sufficiently protected against water & dust. The installation should also be guard against any lightning surge or any other necessary electrical protection as deemed in such typical installation & application.

Product data

General Information	
Application Code	E+
Type Version	mk2
Lamp Type	TL5
Number of Lamps	2 piece/unit
Number of Products on MCB (16A Type B) (Nom)	16
Automatic Restart	Yes

Operating and Electrical	
Input Voltage	195-240 V
Input Frequency	50 to 60 Hz
Operating Frequency (Max)	110 kHz
Operating Frequency (Min)	45 kHz
Ignition Method	Warm Start
Crestfactor (Max)	1.7
Power Factor 100% Load (Nom)	0.95
Ignition Time (Max)	1 s
Mains Voltage Performance (AC)	-8% - +6%

HF-Regulator Intelligent Touch DALI for TL5/TL-D/PL-L lamps

Mains Voltage Safety (AC)	-10%~+10%
Earth Leakage Current (Max)	0.5 mA
Inrush Current Width	0.26 ms
Standby Power Consumption (Max)	0.25 W
Ballast Factor (Nom)	1
Power Losses (Nom)	5.0 W
Inrush Current Peak (Max)	27 A

Wiring

Connector Type Input Terminals	WAGO 251 universal connector [Suitable for both automatic wiring (ALF and ADS) and manual wiring]
Cable Capacity Output Wires Mutual (Max)	200 pF
Connector Type Output Terminals	WAGO 251 universal connector [Suitable for both automatic wiring (ALF and ADS) and manual wiring]
Connector Type Control Input Terminals	WAGO 251 universal connector [Suitable for both automatic wiring (ALF and ADS) and manual wiring]
Wire Striplength	8.0-9.0 mm
Dual Fixture Master/Slave	Yes [Master/Slave operation possible]
Control Input Terminal Cross Section	0.50-1.00 mm ²
Input Terminal Cross Section	0.50-1.00 mm ²
Output Terminal Cross Section	0.50-1.00 mm ²
Auto Insert (ALF/ADS) Wire Cross Section	0.75 mm ²
Cable Capacity Output Wires to Earth (Max)	200 pF

System characteristics

Rated Ballast-Lamp Power	14/21/24/39 W
Rated Lamp Power on TL-D	36 W
System Power on TL-D	69.6 W
Lamp Power on TL-D	64.0 W
Power Loss on TL-D	5.6 W
Rated Lamp Power on PL-L	24/36/40 W
System Power on PL-L	50.0/65.6/82.2 W
Lamp Power on PL-L	45.0/60.0/76.0 W
Power Loss on PL-L	5.0/5.6/6.2 W
Rated Lamp Power on TL5	14/21/24/39 W
System Power on TL5	31.2/45.7/51.1/79.1 W
Lamp Power on TL5	27.4/41.4/46.0/73.0 W
Power Loss on TL5	3.8/4.3/5.1/6.1 W
Rated Lamp Power on TL5 ECO	13/19/20/34 W
System Power on TL5 ECO	28.7/42.8/44.9/71.7 W
Lamp Power on TL5 ECO	25.0/38.2/40.0/66.0 W
Power Loss on TL5 ECO	3.7/4.6/4.9/5.7 W

Temperature

T-Ambient (Max)	50 °C
T-Ambient (Min)	-25 °C
T-Storage (Max)	80 °C

T-Storage (Min)	-40 °C
T-Case Lifetime (Max)	75 °C
T-Case Maximum (Max)	75 °C
Stable Lamp Operation Temperature	15°C
T-Ignition (Max)	50 °C
T-Ignition (Min)	-25 °C

Controls and Dimming

Control Interface	TD
Regulating Level Power	1%-100%
Control Input Protection	Yes (Basic insulation)

Mechanical and Housing

Housing	L 360x30x21
---------	-------------

Emergency Operation

Battery Voltage Lamp Ignition	198-254 V
Battery Voltage Lamp Operation	176-254

Approval and Application

Energy Efficiency Index	A1 BAT
IP Classification	IP 20 [Ingress Protection 20]
EMI 9 kHz ... 30 MHz	EN55015
EMI 30 MHz ... 1000 MHz	EN 55022 Class B
Safety Standard	IEC 61347-2-3
Performance Standard	IEC 60929
Quality Standard	ISO 9000:2000
Environmental Standard	ISO 14001
Harmonic Current Emission Standard	IEC 61000-3-2
EMC Immunity Standard	IEC 61547
Vibration Standard	IEC68-2-6 F c
Bumps Standard	IEC 68-2-29 Eb
Humidity Standard	EN 61347-2-3 clause 11
Approval Marks	CE marking ENEC certificate VDE-EMV certificate
Temperature Marking	Yes
Emergency Standard	IEC 60598-2-22
Hum And Noise Level	Inaudible

Product Data

Full product code	871829169691900
Order product name	HF-Ri TD 2 14/21/24/39 E+
EAN/UPC - Product	8718291696919
Order code	913700698466
Numerator - Quantity Per Pack	1
Numerator - Packs per outer box	12
Material Nr. (12NC)	913700698466
Net Weight (Piece)	0.316 kg

HF-Regulator Intelligent Touch DALI for TL5/TL-D/PL-L lamps

Dimensional drawing

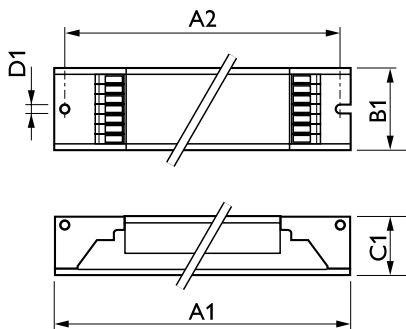

Product	D1	C1	A1	A2	B1
HF-Ri TD 2 14/21/24/39 E+	4.1 mm	21.0 mm	360.0 mm	350.0 mm	30.0 mm

HF-Ri TD 2 14/21/24/39 TL5 E+ 195-240V

