

Product selected: EFN 12V 75W

### Applications

- Microfilm readers
- Medical equipment
- Fiber optic applications
- Enlargers
- Overhead projectors
- Slide projectors

### Features

- Compact filament
- Perfect alignment of the burner
- Highly efficient reflector/lamp combination
- Dichroic reflector, which radiates 75% of heat rearwards

### Directions for use

- No dimming lower than 10% of rated voltage

### Product Attributes

Item description	EFN 12V 75W
Ordering Code	0061342
EAN code	5410288613420
Packing Quantity	100
Watt. (W)	75
Volt. (V)	12
Cap	GZ6.35
Max. Over. Length (mm)	42
Diameter (mm)	50
Light output (lm)	550
ANSI code	EFN
LIF code	A1/230
Working Distance (mm)	32
Colour Temp (K)	3400
Average life (hours)	50
Reflector Surface	Smooth
Burning position (image)	S105

### Burning Position

### Product Image



### Line Drawing

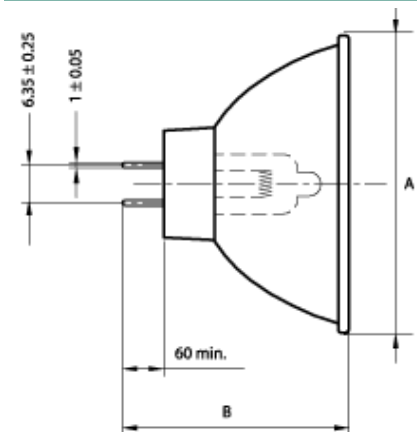

### Lamp Cap

