

Dimensions

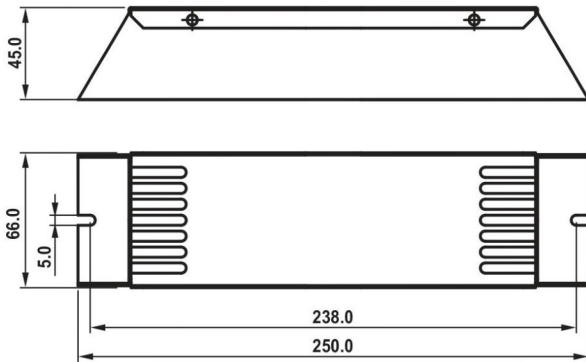

Wiring Diagram

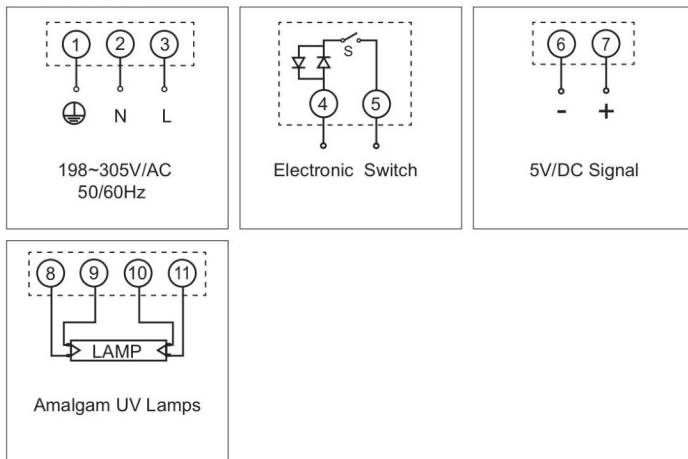

RH8-AL-200

AC Source :	198~305V	Lamp Power :	100~200W
Mains Frequency :	47~63Hz	Output Current :	1.2A/1.5A/1.8A/2.1A typ.
Input Power :	115~220W	Output Frequency :	33~50KHz
Input Current :	Max.0.95A at 230Vrms	Preheat Time :	1.1A/1.3A/1.5A/2.0A
Power Factor :	0.99 typ.	Preheat Current :	1.1A 1.3A 1.5A 2.0A
		Efficiency :	90% Max. load
Lamp Type : Max.200W/1.2A Max.200W/1.5A Max.200W/1.8A Max.200W/2.1A			

**DIP-switch settings**

ON				
1	2	3	4	5
0	0	0	0	0
Lamp Current Setting	Preheat Current Setting	Preheat Time Setting		

Lamp Current Switches set to	Preheat Current Switches set to	Preheat Time Switches set to
00=1.2A/Max.200W	00=1.1A	0=8S
01=1.5A/Max.200W	01=1.3A	1=12S
10=1.8A/Max.200W	10=1.5A	
11=2.1A/Max.200W	11=2.0A	

RH8-AL-320

AC Source :	198~305V	Lamp Power :	200~320W
Mains Frequency :	47~63Hz	Output Current :	1.8A/2.1A typ.
Input Power :	215~340W	Output Frequency :	30~38KHz
Input Current :	Max.1.53A at 230Vrms	Preheat Time :	12S or 20S
Power Factor :	0.99 typ.	Preheat Current :	1.5A/2.0A
		Efficiency :	94% Max. load
Lamp Type : Max.320W/1.8A Max.320W/2.1A			

**DIP-switch settings**

ON				
1	2	3	4	5
0	0	0	0	0
Lamp Current Setting	Preheat Current Setting	Preheat Time Setting		

Lamp Current Switches set to	Preheat Current Switches set to	Preheat Time Switches set to
00=1.8A/Max.320W	00=1.5A	0=12S
01=2.1A/Max.320W	01=2.1A	1=20S

Features & Functions

- Preheat Start
- Limiting Current and Power
- Lamp Open Protection
- Lamp Fault Protection
- Status Indication / Local
- Lamp status indication via LED indicators  
Green LED = lamp on , Red LED = lamp fault
- Status Indication / Remote
- DC 5V Signal / Optional  
Lamp on: Max.5V/DC Max.5mA, Lamp fault: 0V
- Electronic Switch / Optional  
4~5 on = Lamp on , 4~5 off = Lamp fault
- Optional : Output Current , Preheat Current , Preheat Time

Ordering Information

Type	Quantity [pcs]			Weight [kg]			Size [m³]			Article No.
	A	B	C	A	B	C	B	C		
RH8-AL-200	2	18	648	1.33	12.86	475	0.028	1.36	80 00 0811 05	
RH8-AL-320	2	18	648	1.33	12.86	475	0.028	1.36	80 00 0811 02	

Note: (A: Small box. B: Carton. C: Pallet.)