

Philips medium pressure mercury lamps

We manufacture and internationally distribute a wide range of high quality medium pressure mercury UV lamps. These quartz lamps are available up to 120 Watts per cm, with an arc length of 4 to 140 cm, in a variety of end fittings. The lamps are made from selected types of quartz glass, manufactured at our own factories.

Medium pressure mercury UV lamps

Our medium pressure lamps contain sophisticated quantities of mercury bromides, providing a self-cleaning halogen cycle, to control the decline of UV radiation over lamp life.

Main applications:

- Municipal waste water treatment systems
- Municipal drinking water treatment systems
- Process water treatment systems
- Swimming pool treatment systems

Spectral output

The lamps emit the characteristic spectrum of mercury discharge lamps. The HOK and HTK types also radiate wavelengths below 240 nm, whereby ozone is formed. The special quartz of the HTQ lamps absorbs radiation below 240 nm.

Features	Benefits
Self cleaning halogen cycle	Better maintenance of lamps, no over-designing necessary, cost saving

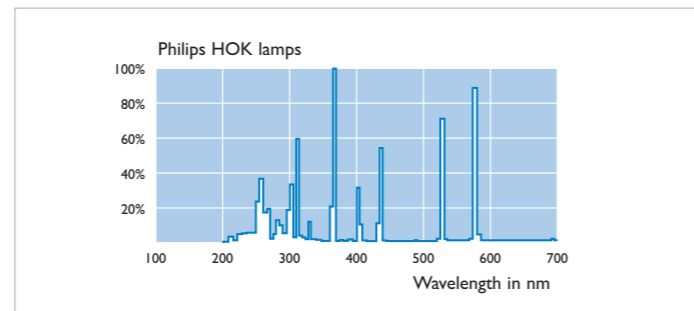
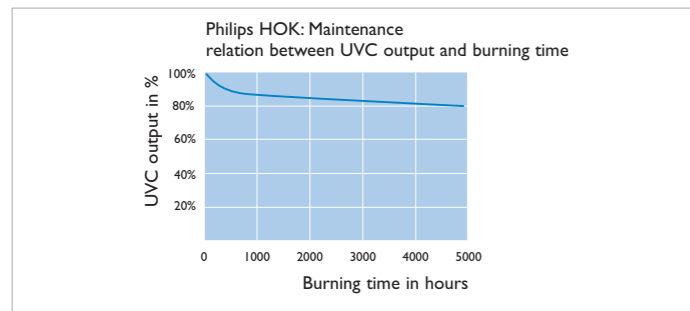

Philips HOK lamps										
Type	Tube diameter mm	Arc length mm (X)	Lamp wattage (W)	Lamp voltage (V)	Overall lamp length (Y)	Lamp current (A)	UVC >210 nm (W)	UVB (W)	UVA (W)	μW/cm ² at 1 meter
Philips HOK 4/120	14	29	400	125	104.0	3.5	53	32	31	488
Philips HOK 4/120 SE*	14	29	400	125	110.0	3.5	53	32	31	488
Philips HOK 20/100	22	195	2000	245	262.0	9.6	325	198	175	2990
Philips HOK 35/120	22	348	4300	510	428.0	10.3	759	403	351	6983
Philips HOK 50/120	22	500	6000	1050	580.0	10.0	1060	546	462	9752
Philips HOK 65/120	22	637	7800	910	717.0	10.3	1278	741	722	11758
Philips HOK 80/120	22	800	9600	1080	880.0	10.5	1568	926	829	14426
Philips HOK 105/120	22	1057	12400	1430	1137.0	10	2021	1244	1042	18593
Philips HOK 140/120	22	1407	17000	1920	1487.0	10.0	2860	1646	1380	26312
Philips HTK 7/60	14	700	4000	1400	770.0	3.1	593	380	321	5456
Philips HTQ 7	14	700	2000	1400	762.5	1.7	130	165	142	1196
Philips HTQ 14	22	1400	4000	1400	1485.0	3.1	280	350	300	2576
Philips HOK 10/120L	22	106	1000	145	232.0	7.5	135	80	80	1250
Philips HOK 15/120L	22	151	1450	150	277.0	10.0	185	135	128	1720
Philips HOK 20/120L	22	204	2000	240	332.0	9.7	280	180	175	2570
Philips HOK 25/120L	22	254	2800	275	382.0	10.0	466	280	255	4290

* SE = single ended **Note:** Permissible bulb temperatures: HOK: 600 - 900°C HTK, HTQ: 500 - 700°C
Permissible pinch temperatures: 300°C
Please contact us for details on dimensions and tolerances

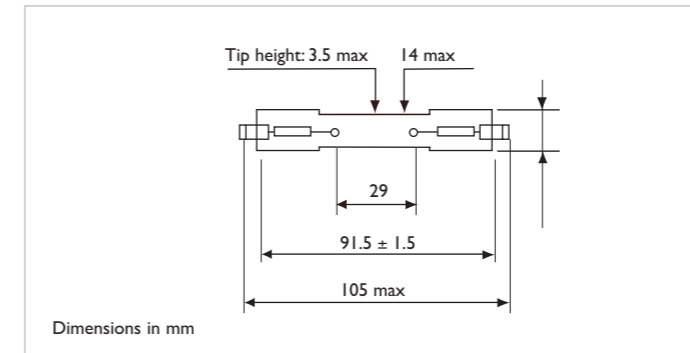

Philips HOK 4/120

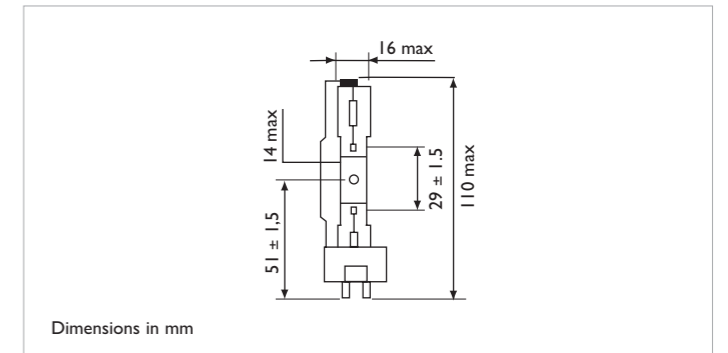

Philips HOK 4/120 SE

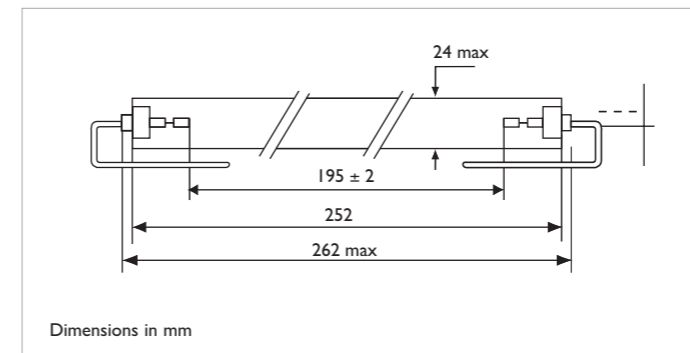

Philips HOK 20/100

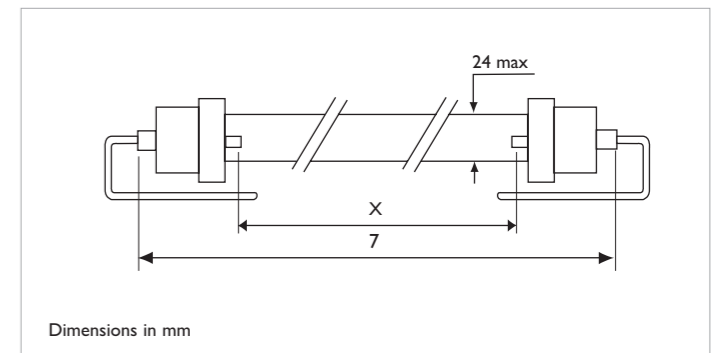

Philips HOK 35/120, HOK 50/120, HOK 65/120, HOK 80/120, Philips HOK 105/120, HOK 140/120

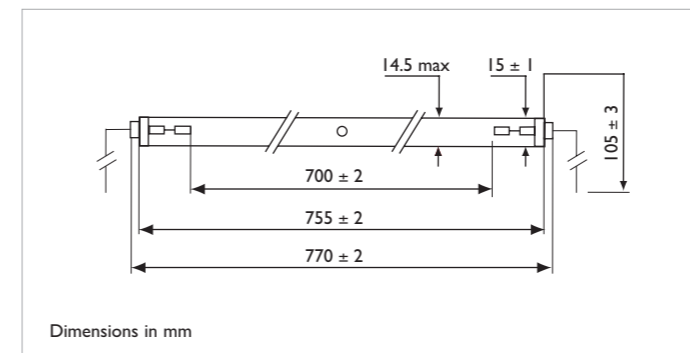

Philips HTK 7/60

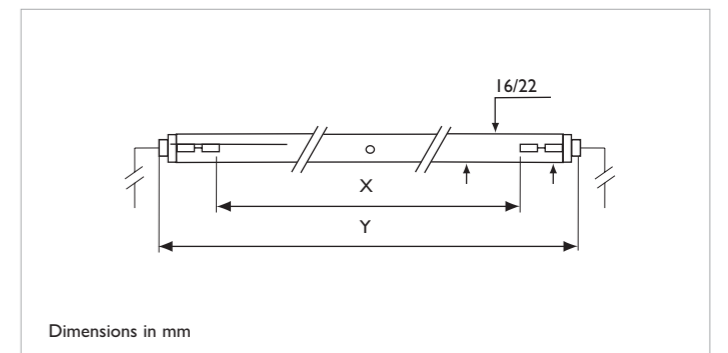

Philips HTQ 7, HTQ 14

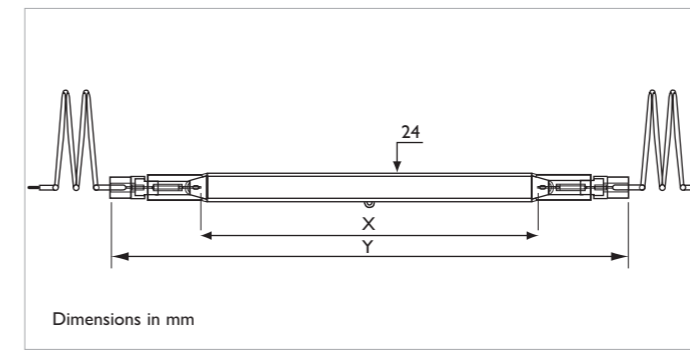

Philips HOK 10/120L, HOK 15/120L, HOK 20/120L, HOK 25/120L

Note: please contact us for details on dimensions and tolerances.