

Features

- Utilizes a CREE XM-L U2 LED
- Maximum output of up to 900 lumens
- Integrated "Precision Digital Optics Technology" provides extreme reflector performance
- Boasts a peak beam intensity of 60,000cd and a throw distance of up to 490 meters
- Innovative single button two-stage switch offers a user-friendly interface (patented)
- Eight rapidly switchable brightness modes to select from
- High efficiency circuit board provides up to 800 hours runtime
- Integrated power indicator light displays remaining battery power (patented)
- Power indicator's secondary function displays battery voltage (accurate to 0.1V)
- Reverse polarity protection prevents damage due to incorrectly inserted batteries
- Stainless steel retaining ring protects the core components from damage
- Toughened ultra-clear mineral glass with anti-reflective coating
- Constructed from aero grade aluminum alloy
- Sturdy HAIII military grade hard-anodized
- Waterproof in accordance with IPX-8 (two meters submersible)
- Impact resistant to 1.5 meters
- Tail stand capability

Dimensions

Length: 183mm (7.17")
 Head diameter: 60 mm (2.36")
 Tube diameter: 41.8mm (1.65")
 Weight: 302g (10.65oz)(without battery)

Accessories

Quality holster, lanyard, spare O-ring

Battery Options

	SIZE	Nominal voltage	Usability
Primary AA battery	AA	1.5V	Y (Recommended)
Rechargeable AA battery	AA	1.2V	Y (Recommended)
Primary AA Lithium battery	L91	1.5V	Y
Primary LiFePO4 battery	14500	3.2V	N (Banned)
Rechargeable Li-ion battery	14500	3.7V	N (Banned)

Output & Runtime

FL1 STANDARD	TURBO	HIGH	MID	LOW	LOWER
	900 LUMENS	590 LUMENS	180 LUMENS	50 LUMENS	2 LUMENS
	2h	3h45min	14h	60h	800h
	490m (Beam Distance)				
	60000cd (Peak Beam Intensity)				
	1.5m (Impact Resistant)				
	IPX-8, 2m (Waterproof AND Submersible)				

NOTICE

The above data has been measured in accordance with the international flashlight testing standards ANSI/NEMA FL1 using 8 x 1.2V 2400mAh AA batteries under laboratory conditions. The data may vary slightly during real-world use due to battery type, individual usage habits and environmental factors.

NITECORE (SYSMAX) is a member of PLATO, participating in and helping to develop the ANSI FL1 standard of measurement. Product testing data is in accordance with these internationally recognized scientific standards.

Battery installation

1. Insert batteries with the positive (+) and negative (-) ends corresponding to the diagram on the inside of the battery compartment.
2. Tighten the tail cap by aligning the two gold pins on the inside of the tail cap with the corresponding holes on the flashlight body and rotate clockwise.

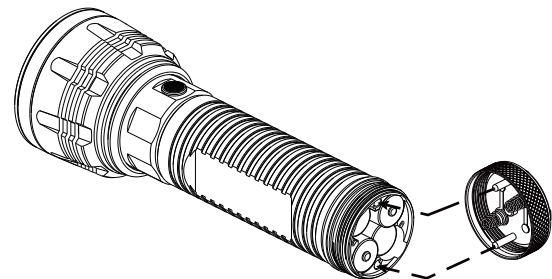
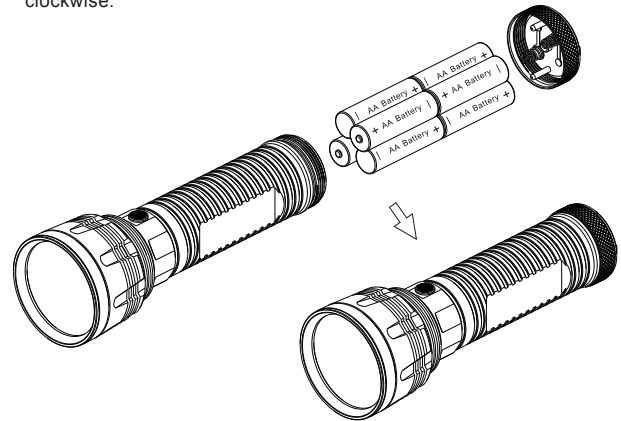

Tips

Inserting batteries in a dark environment: Two of the four battery slots in the EA8's battery compartment feature grooves indicating that batteries should be inserted with the negative (-) ends facing forward, while the two slots with no grooves require the batteries to be inserted with the positive (+) ends facing forward. In this way, batteries can be inserted correctly through tactile feedback alone.

After loading the batteries, the power indicator light will blink to indicate the battery voltage. Please refer to the "Power Tips" section of this manual for details.

WARNING

1. Insert batteries using the image on the inside of the battery compartment as a reference.
2. Do not mix rechargeable and non-rechargeable batteries.
3. Do not mix batteries of different types/brands.

General Operation

The EA8 utilizes a 2-stage switch similar to a camera shutter button. The light's numerous functions are selected according to the depth the switch is pressed. The EA8 has two modes: Daily mode and Search / Turbo mode.

Operating In Daily Mode

1. With the light turned off, press the switch partway down and release within a second to enter daily mode.
2. Daily mode contains four brightness levels: ultra-low, low, medium, and high. Pressing the switch partway down in quick succession will cycle through these modes. Pressing the switch partway down and holding for more than one second when in daily mode will enter into turbo mode. See Turbo / Search mode instructions below.
3. The light is turned off (put into standby mode) by pressing the button all the way down and releasing within a second. This will also memorize the last daily mode used.

NITECORE®

ALL-ROUND Flashlight Expert

4. Daily mode has a momentary function which allows the light to be turned on only when the switch is held. With the light turned off, press the switch partway down and hold to activate daily mode's momentary function. The light will turn off the moment the switch is released.

Operating in Search / Turbo Mode

1. With the light turned off, press the switch all the way down and release within one second to enter turbo mode. To cycle between high and turbo modes press the button partway down while in turbo mode.
2. To turn the light off when in turbo mode, once again press the button all the way down and release within one second.
3. With the EA8 turned on in Search/Turbo mode, partway presses of the button will cycle between high and ultra-high mode. There is no memory function in Search/Turbo mode.

Standby Mode / Lockout and Unlock functions

With the light turned on, press the switch all the way down and release within one second to enter into standby mode. In this mode, the light will consume small amounts of power to maintain the settings in the MCU (micro control unit) but appear to be turned off. When in standby mode the power indicator light will flash once every three seconds to show the location of the light.

With the light turned on, press the switch all the way down and hold for more than one second. The light will turn off and enter into lockout mode. Lockout mode consumes almost no battery power and prevents the light from accidentally turning on. Holding the switch for more than one second to exit the lockout mode.

NB: When entering lockout mode, the power indicator will flash to indicate specific battery voltage. Please refer to the "Power Tips" section of this manual for details.

Special Strobe / SOS mode and Location Beacon

With the light turned on, press the switch all the down twice in quick succession to enter strobe mode. When in strobe mode, press the switch all the way down and hold for more than one second to cycle through strobe, SOS and location beacon modes. To select any of these modes simply release the switch when it is displayed. To turn off the light fully press and release the switch.

Power Tips

1. When the light is on, the power indicator will blink once every two seconds when power levels reach 50%.
2. When the light is on, the power indicator will blink consistently when power levels are low.
3. Each time batteries are inserted or the light is put into lockout mode, the power indicator light will blink in various patterns to indicate the battery voltage (accurate to $\pm 0.1V$). For example, when the battery voltage is at a maximum charge of 4.2V, the power indicator will blink 4 times in quick succession, followed by a one second pause and two more blinks, indicating a total battery voltage of 4.2V.

Changing / Charging Batteries

When the power indicator blinks rapidly it means the batteries need to be replaced or recharged. Alternatively if the light becomes dim or unresponsive to adjustment this also indicates batteries need to be replaced or recharged.

Maintenance

Every 6 months, threads should be wiped with a clean cloth followed by a thin coating of silicon-based lubricant.

Warranty Service

All NITECORE® products are warranted for quality. DOA / defective products can be exchanged for replacement through a local distributor/dealer within the 14 days of purchase. After 14 days, all defective / malfunctioning NITECORE® products will be repaired free of charge for a period of 18 months from the date of purchase. After 18 months, a limited warranty applies, covering the cost of labor and maintenance, but not the cost of accessories or replacement parts. The warranty is nullified in all of the following situations:

1. The product(s) is/are broken down, reconstructed and/or modified by unauthorized parties.
2. The product(s) is/are damaged through improper use.
3. The product(s) is/are damaged by leakage of batteries.

For the latest information on NITECORE® products and services, please contact your national NITECORE® distributor or send an email to service@nitecore.com



Please follow our facebook for more info: NITECORE Flashlights

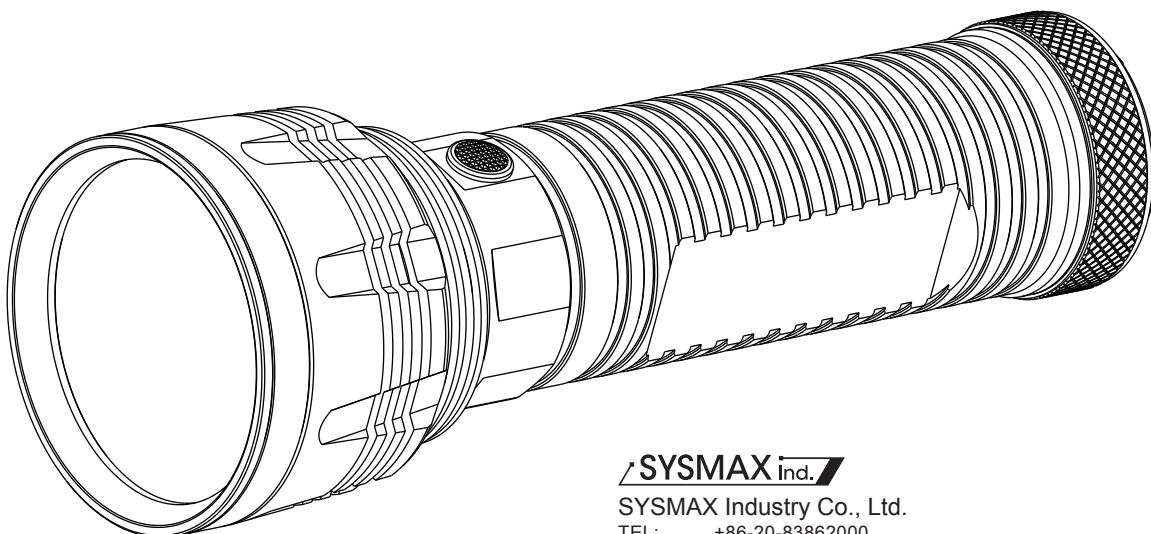

SYSMAX ind.

SYSMAX Industry Co., Ltd.

TEL: +86-20-83862000

FAX: +86-20-83882723

E-mail: info@nitecore.com

Web: www.nitecore.com

Address: Rm1407-08, Glorious Tower, 850 East Dongfeng Road, Guangzhou, China 510600



Thanks for purchasing NITECORE!