



MASTER LEDspot LV

MASTER LEDspotLV 4.5-20W 827 MR16 24D

Delivering a warm, halogen-like accent beam, MASTER LEDspot LV is an ideal retrofit solution for spot and general lighting applications in the hospitality industry. It is particularly suited to public areas such as receptions, lobbies, corridors, stairwells and washrooms, where the light is on all the time. The robustly designed MASTER LEDspot offers a choice of beam angles for a clearly defined beam spread. There is no UV or IR in the beam, making it suitable for illuminating heat-sensitive objects (food, organic materials, paintings, etc.). The patented intelligent driver enables broad compatibility with existing electromagnetic and electronic halogen transformers. The dimmable versions drive further efficiencies, while helping to create the desired atmosphere.

Product data

• General Characteristics

Cap-Base	GU5.3
Bulb	MR16 [MR 16inch/50mm]
Rated Lifetime (hours)	40000 hr
Nominal Lifetime hours	40000 hr

• Light Technical Characteristics

Color Code	827
Color Designation (text)	Warm White
Beam Angle	24 D
Correlated Color Temperature	2700 K
Luminous Flux	207 Lm
Luminous Intensity	600 cd
Color rendering index	80
Luminous Efficacy Lamp	51.75 Lm/W
Color Temperature	2700 K [CCT 2700K]
Rated Luminous Flux	207 Lm
LLMF - end nominal lifetime	70 %
Colour consistency	6 steps
Rated Beam Angle	24 D
Luminous flux in 90° cone	207 Lm

• Electrical Characteristics

Wattage	4 W
Wattage Technical	4.5 W
Voltage	12 V
Line Frequency	50-60 Hz

Power Factor	0.7 -
Lamp Current mA	491 mA
Dimmable	No
Wattage Equivalent	20 W
Rated Wattage	4.5 W
Starting Time	0.1 (max) s
Warm-up Time to 60% Light Outp	instant full light
Suitable for accent lighting	Yes

• Temperature Characteristics

• Environmental characteristics

Energy Efficiency Label (EEL)	A
-------------------------------	---

• Measuring Conditions

Switching cycle	50000X
-----------------	--------

• Product Dimensions

Overall Length C	50 mm
Diameter D	48.3 mm

• Product Data

Order code	929000265102
Full product code	929000265102
Full product name	MASTER LEDspotLV 4.5-20W 827 MR16 24D
Order product name	MAS LEDspotLV 4.5-20W 827 MR16 24D
Pieces per pack	1



PHILIPS

MASTER LEDspot LV

Packing configuration 10
Packs per outerbox 10
Bar code on pack - EAN1 8718291722366
Bar code on outerbox - EAN3 8718291722373

Logistic code(s) - 929000265102
12NC
Net weight per piece 0.060 kg

Warnings and Safety

- Operating temperature range is between -20° C and 45° C ambient

- Only to apply in dry or damp locations and most of open fixtures with lamp-holders that offer sufficient space (10 mm free air space)
- Not intended for use with emergency light fixtures or exit lights

Dimensional drawing

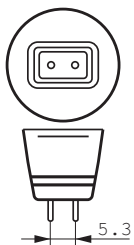
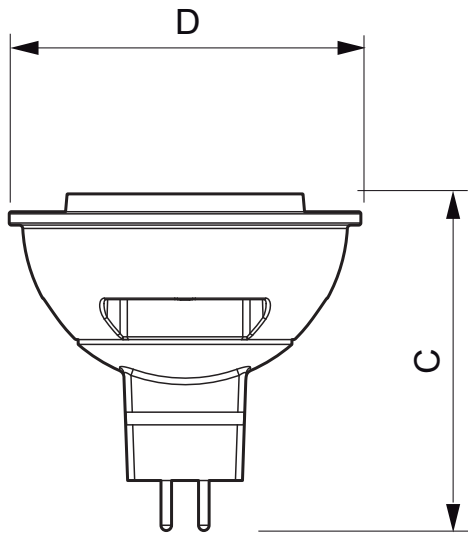

GU5.3

MASTER LEDspotLV 4.5-20W 827 MR16 24D

Product	C (Norm)	D (Norm)
LED 4.5-20W 827 MR16 24D	50	48.3



© 2014 Koninklijke Philips N.V. (Royal Philips)
All rights reserved.

Specifications are subject to change without notice. Trademarks are the property of Koninklijke Philips N.V. (Royal Philips) or their respective owners.

www.philips.com/lighting

2014, September 4
data subject to change