



PrimaVision for CDM Elite MW

HID-PV 315 /S CDM 220-240V 50/60Hz

Highly reliable electronic drivers for medium-wattage lamps: 80,000 hours lifetime for the Xtreme version and 50,000 hours for the non-Xtreme versions

Product data

General Information	
Type Version	mk1
Lamp Type	CDM
Number of Lamps	1 piece/unit
Suitable For Outdoor Use	Yes
Number of Products on MCB (16A Type B) (Nom)	4
Default Lamp Selected	CDM315
Automatic Restart	Yes
Operating and Electrical	
Input Voltage	220 to 240 V
Input Frequency	50 to 60 Hz
Minimum Mains Voltage Operation (Min)	198 V
Operating Frequency (Nom)	0.11 kHz
Ignition Switch-Off Time (Nom)	30 min
Mains Voltage Performance (AC)	-8%~+6%
Mains Voltage Safety (AC)	-10%~+10%
Earth Leakage Current (Max)	0.5 mA
Output Peak Voltage (Max)	4000 V
Lamp Power Tolerance	-3%/+3%

Input Current (Nom)	1.53 A
Wiring	
Wire Striplength	10.0 mm
Ballast Contact Wire Cross Section	0.75-2.50 mm ²
Connector Type	Insert
System characteristics	
Rated Ballast-Lamp Power	315 W
Rated Lamp Power on CDM	315 W
System Power on CDM	340.5 W
Lamp Power on CDM	315.0 W
Power Loss on CDM	25.5 W
Temperature	
T-Ambient (Max)	55 °C
T-Ambient (Min)	-20 °C
T-Storage (Max)	80 °C
T-Storage (Min)	-25 °C
T-Case Switch Off (Min)	90 °C

PrimaVision for CDM Elite MW

Controls and Dimming

Programmable Lamp Settings	-
Pre-Set Integrated Controls	-
Programmable Dimming Options	-

Mechanical and Housing

Housing	/S
---------	----

Approval and Application

IP Classification Luminaire	34
Overvoltage Protection 400Vac	5 min
Active Temperature Protection	Yes
Safety Standard	EN60928, 60926
Quality Standard	ISO 9000:2000
Environmental Standard	ISO 14001
Harmonic Current Emission Standard	IEC 61000-3-2
Vibration Standard	IEC 68-2-6 Fc (10-150Hz, 2G)

Bumps Standard	IEC 68-2-29 Eb (10G/16ms)
Humidity Standard	EN 61347-2-12 clause 11
Approval Marks	CE marking ENEC certificate CB Certificate
Hum And Noise Level	37 dB(A)

Product Data

Full product code	872790084311800
Order product name	HID-PV 315 /S CDM 220-240V 50/60Hz
EAN/UPC - Product	8711500880888
Order code	913700639466
Numerator - Quantity Per Pack	1
Numerator - Packs per outer box	4
Material Nr. (12NC)	913700639466
Net Weight (Piece)	2.500 kg

Dimensional drawing

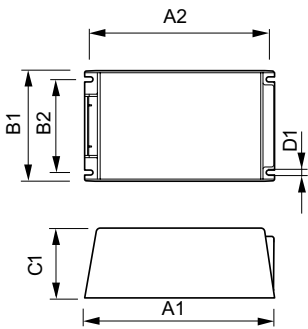

HID-PV 315 /S CDM 220-240V 50/60Hz

Product	D1	C1	A1	A2	B1	B2
HID-PV 315 /S CDM 220-240V 50/60Hz	4.2 mm	60.0 mm	215.0 mm	204.5 mm	128.5 mm	111.5 mm

